



Ready For More.

More uptime, under the toughest conditions and the most challenging duty cycles. More fuel savings.

More productivity. More extended service intervals. More life-to-overhaul. All this is made possible

by Cummins QSK95. The most powerful 16-cylinder high-speed engine ever built for locomotives,

mine trucks, offshore platforms, power generation and marine vessels.

4000HP
35MW

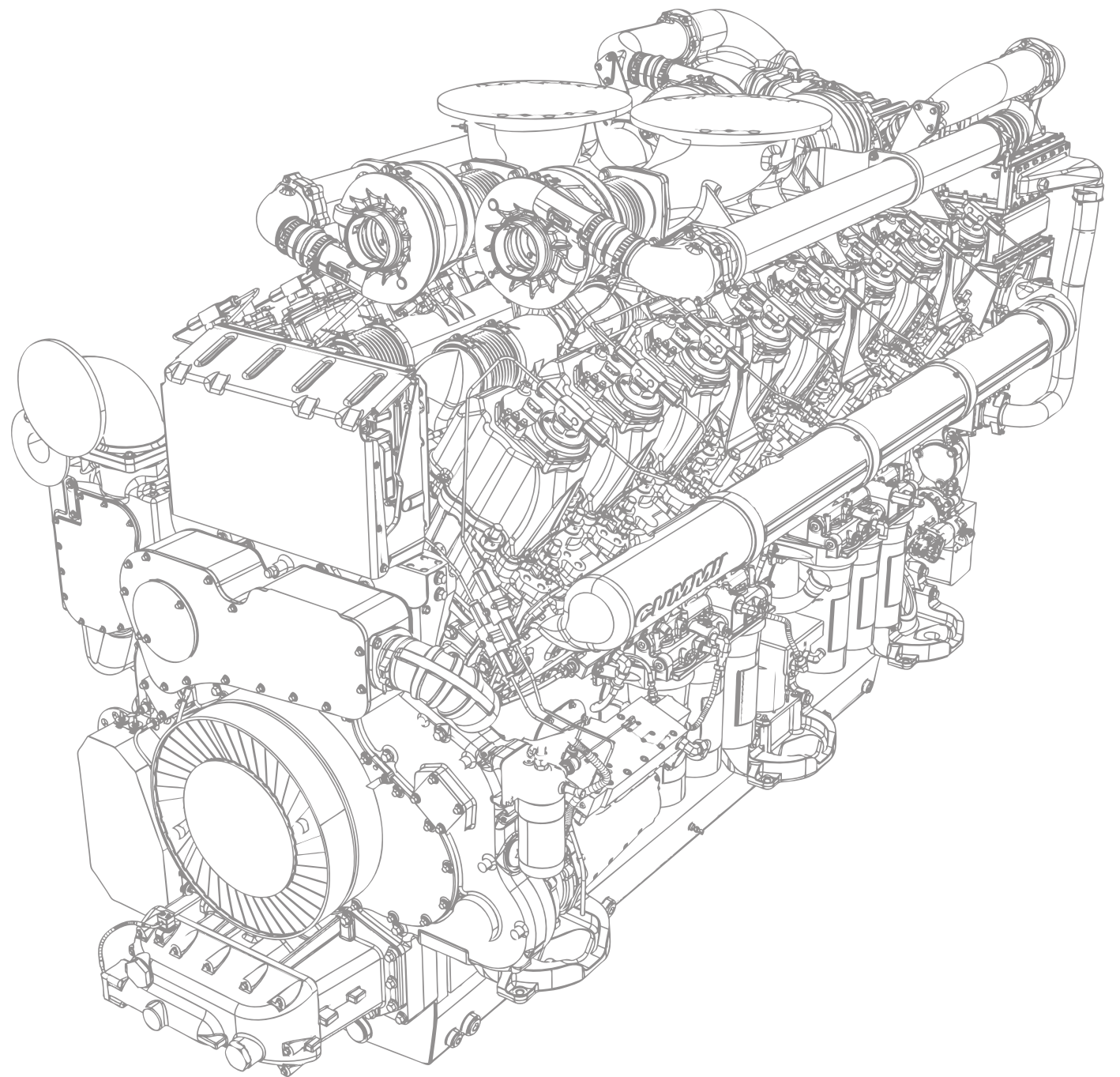

QSK95

The QSK95 is designed to challenge high-speed engines that require 20 cylinders to achieve the same output. And it's far more compact and cost-effective than medium-speed engines at this horsepower. Plus, it can be supplied by Cummins as a ready-to-install offshore-drilling power module for oil and gas platforms. Or as a fully integrated generator set with up to 3.5-MW output. The results are clear to see: An exceptionally strong engine that has outstanding power delivery – yet runs remarkably clean, quiet and smooth for an engine with over 4000 horsepower. It took 150 engineers to design the QSK95 and more than a \$100 million investment to establish a new production line and test facility at Cummins Seymour Engine Plant in Indiana. **And that is just the beginning.**

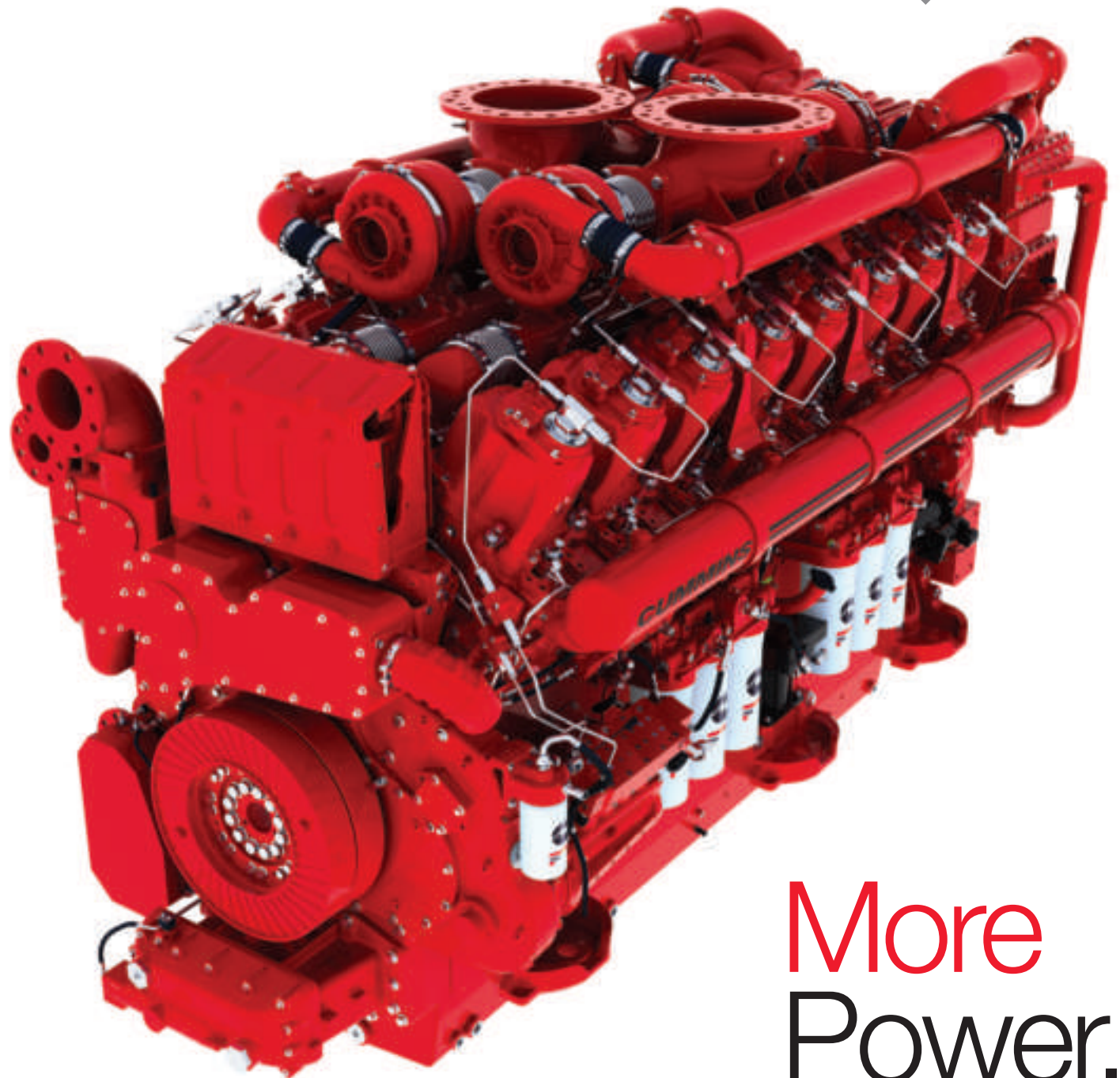

More Power.

More Performance.

Ready to set new standards of uptime availability and lower cost of operation with best-in-class fuel efficiency. Expect a minimum of 500-hour service intervals and faster maintenance procedures, with all key points externally mounted for ease of access. And expect exceptionally long life-to-overhaul from the QSK95 – even under the most severe duty cycle conditions.

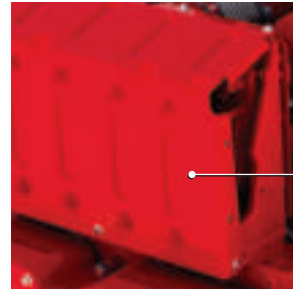

MCRS Fuel System

Cummins next-generation Modular Common Rail System (MCRS) enables the QSK95 to achieve exceptionally low fuel consumption for its power output. MCRS reduces noise, offers smooth idle stability and eliminates visible smoke across the entire operating range.

QSK95 Power Range

Locomotive	3500 – 4200 hp	(2610 – 3132 kWm)
Marine	3200 – 4000 hp	(2386 – 2983 kWm)
Mining	4000 hp	(2983 kWm)
Offshore Drilling	3000 hp	(2237 kWm)
Power Generation	3000 – 5100 hp	(2237 – 3803 kWm)

ECM Group

4 x standardized Cummins Electronic Control Modules (ECMs) provide high levels of processing power and memory to monitor, control and protect engine systems. Grouped together for easy access at the front of the engine in a protected cover. Each ECM monitors an engine quadrant. Provides easy interface with equipment control systems and potential for worldwide remote monitoring with prognostics and diagnostics over available networks.

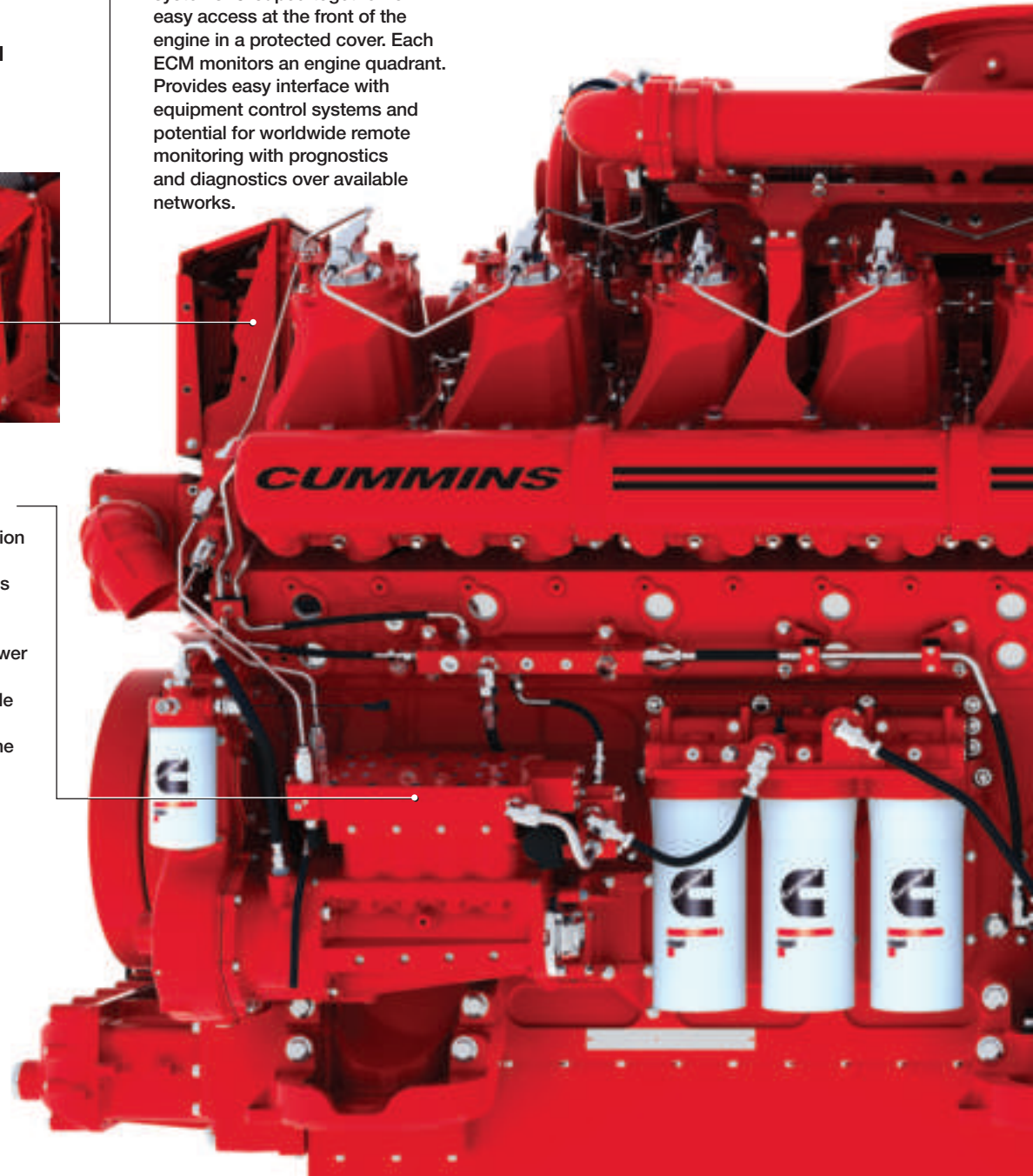

MCRS Injectors

Capable of up to 2200-bar pressure to reduce Particulate Matter (PM) emissions and optimize fuel efficiency for each duty cycle.

More efficient accumulator common-rail architecture avoids the need for a long, exposed traditional common rail.

Features dual-wall fuel lines for added strength and protection.

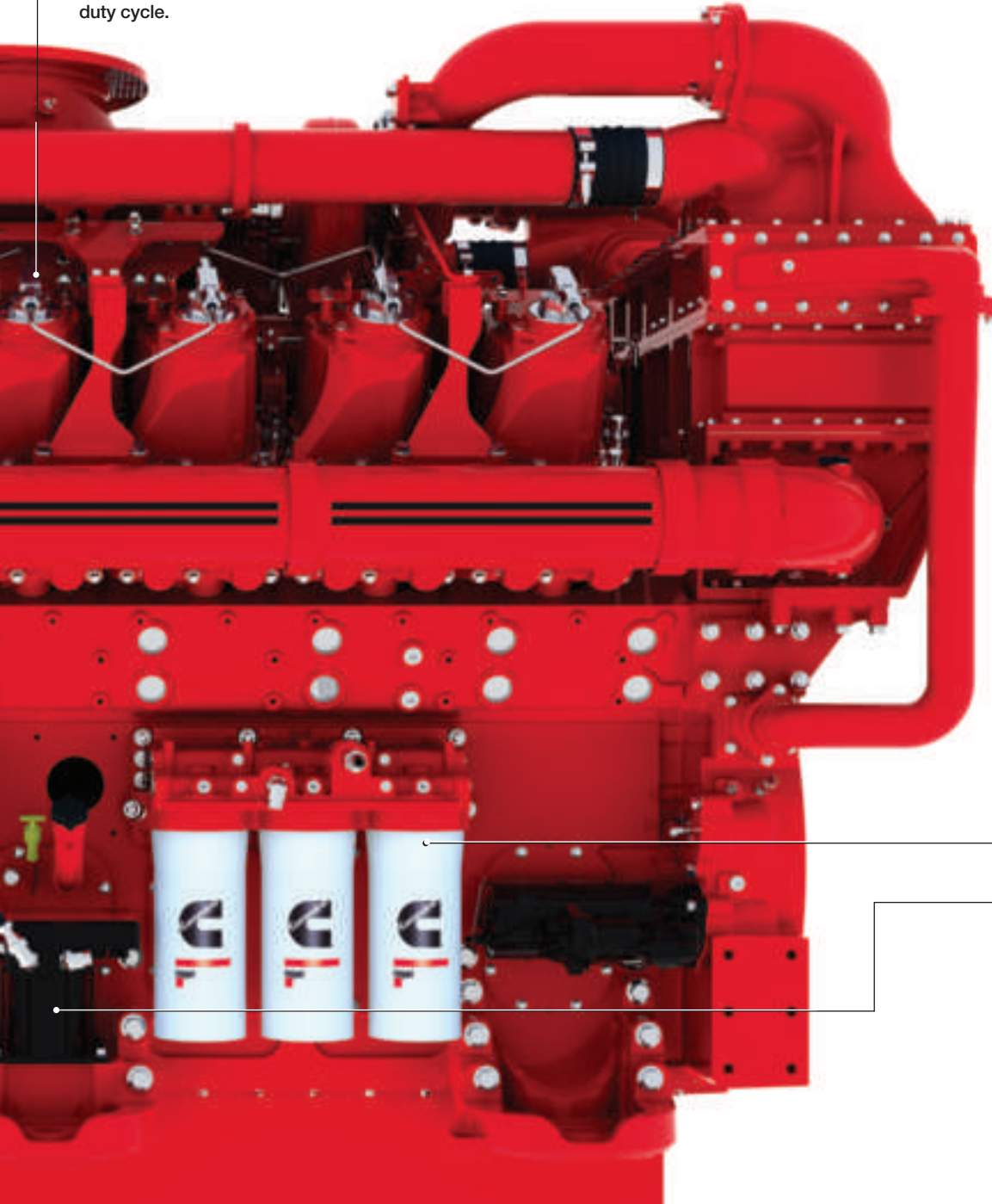

CENTINEL™ Oil Management

Optional CENTINEL system enables oil-change intervals to be dramatically extended to thousands of hours. Automatically replenishes oil based on engine-load factors.



Single-Stage Quad-Turbochargers

4 x compact turbochargers, with one arranged for each bank of four cylinders. Proven single-stage air-handling system with outstanding step load acceptance and transient response.

NanoNet™ Fuel Filtration

Latest NanoNet filtration media, patented by Cummins, gives superior fuel cleanliness and significantly enhances durability of high-pressure fuel system. 3 x Stage I and 3 x Stage II fuel filters are all cartridge-style canisters. Eliminates the need for off-engine fuel filtration and provides 500-hour change intervals.

Electric Fuel Transfer Pump

Heavy-duty pump with variable flow capability enables faster engine priming and delivers exact flow quantity to maximize fuel filter performance. Excellent lift capability to work with a variety of installation fuel tank locations.

More Strength.

The QSK95 is designed with immense strength at the heart of the engine, enabling the power cylinder to achieve higher levels of peak cylinder pressure. As a result, enhanced combustion enables the engine to meet tougher emissions standards while reducing fuel consumption. A stronger engine means more reliability and that there is less to rebuild at engine overhaul, which considerably reduces total life cycle costs.

QSK95 Configuration

95 Liters

16 Cylinders

1200–1800 RPM High-Speed Diesel

Single-Stage Quad-Turbocharging

High-Pressure Fuel Injection



Ductile Iron Block

Highest structural strength achieved with ductile iron and the extended block skirt to improve ability for multiple overhauls with minimal remanufacturing, which reduces costs. An internal stiffening bedplate minimizes installed vibration and increases durability. Improved serviceability through the use of large hand holes.

Two-Stage Aftercooling

A single rear-mounted aftercooler optimizes intake manifold air temperature. Two-stage system reduces radiator sizing and cost by more effectively balancing the heat load between LTA (Low-Temperature Aftercooler) and JW (Jacket Water) circuits. Cooling system is simplified with a single water pump to drive LTA and JW, with a coolant water-leak-free seal.

Leak-Free Seals

Premium “press in place” seals on all critical joints such as flywheel housing, gear housing and oil pan-to-cylinder block joints achieve the goal of a leak-free engine.

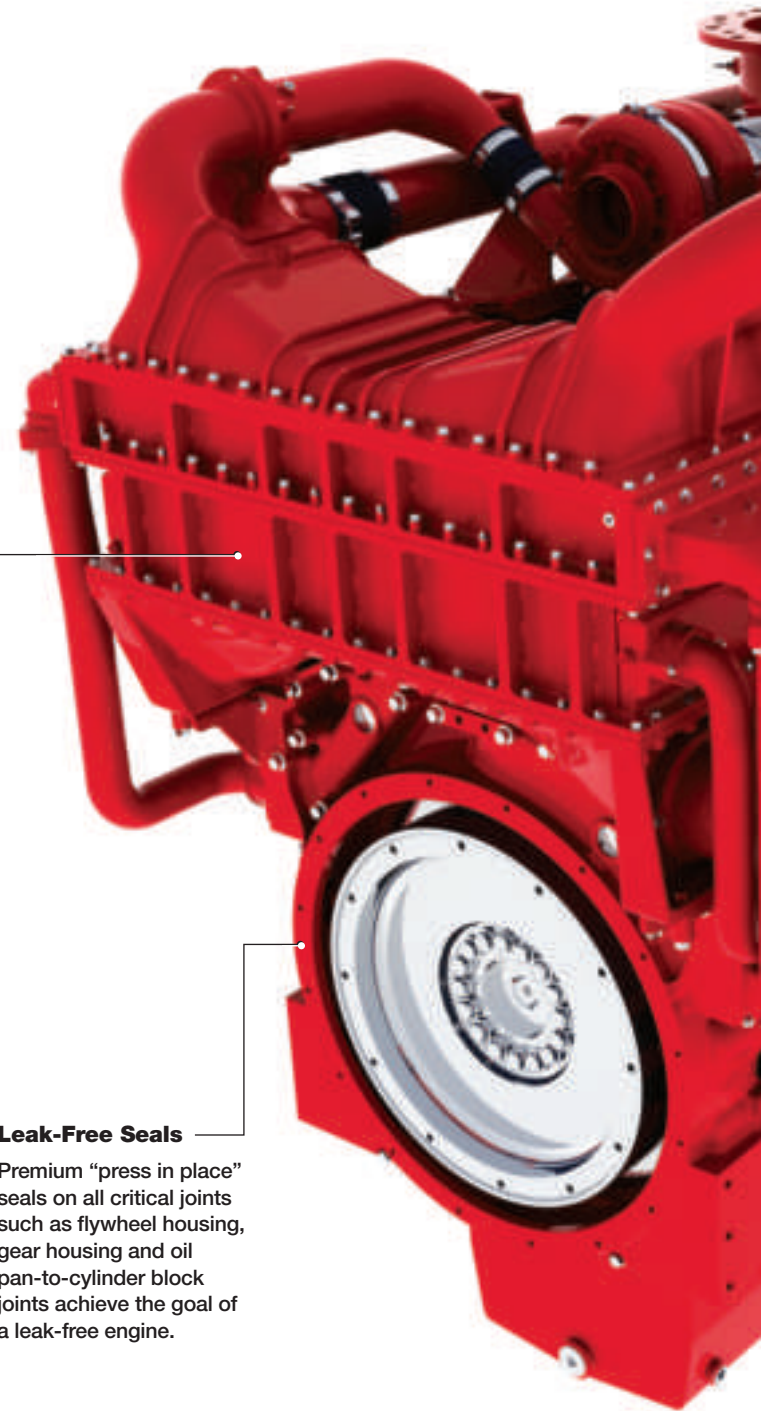

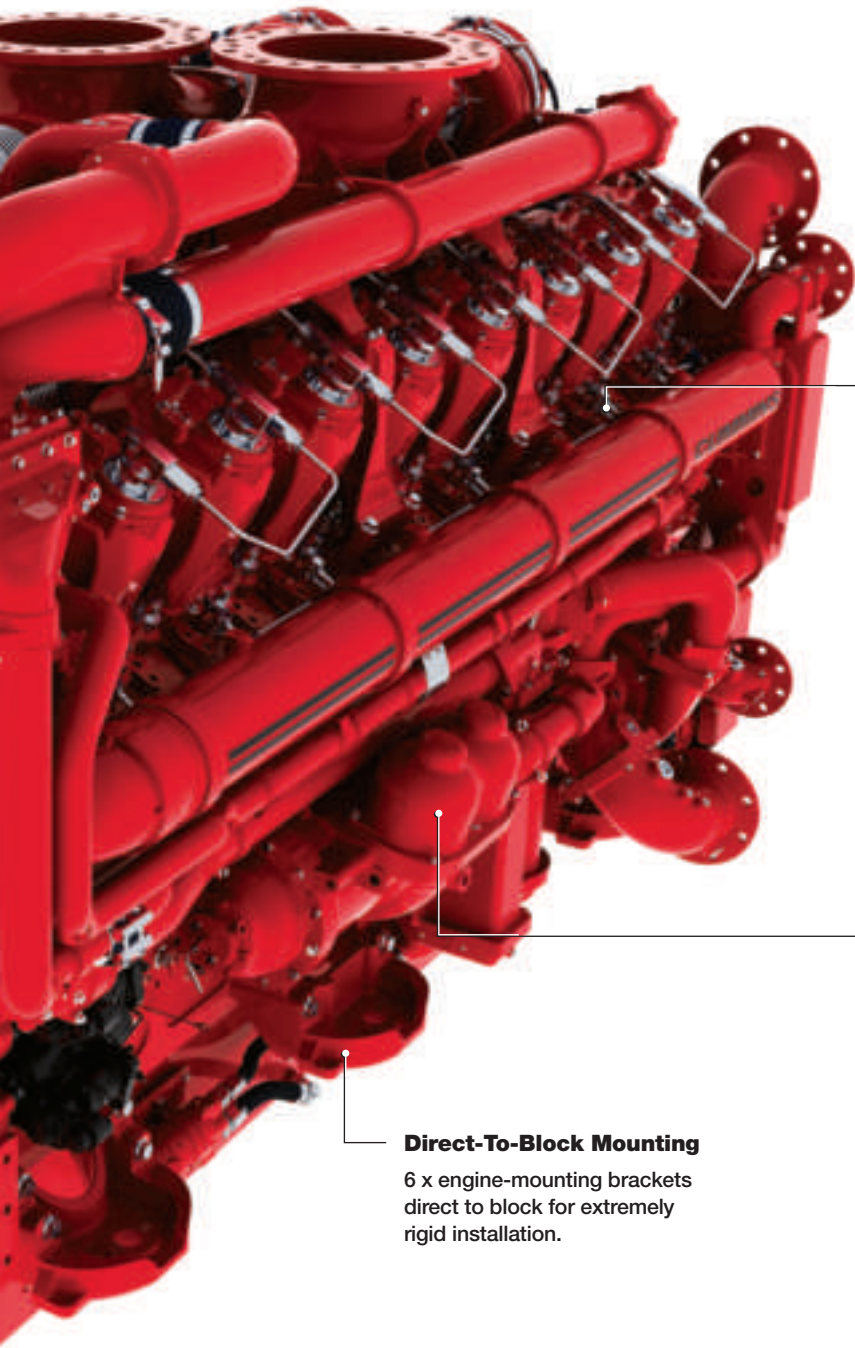

Cylinder Head

Hydraulic tensioning method for cylinder head bolts ensures uniform load for improved reliability and improved serviceability due to the high torque values required. A perimeter seal guarantees that airborne debris cannot penetrate this critical sealing interface. This reduces rebuild costs by minimizing the need to machine head deck at overhaul.

ELIMINATOR™ Oil Filtration Option

Expect a minimum of 500-hour oil-service intervals from the QSK95. Highly efficient, centrifugal self-cleaning system eliminates the need for five spin-on filters and their disposal costs. Service cleaning required only at 1,500 hours or longer.

Direct-To-Block Mounting

6 x engine-mounting brackets direct to block for extremely rigid installation.



Forged-Steel Piston

A single-piece forged-steel piston with exceptional durability provides reuse capability at rebuild. All three piston rings use premium materials, with top ring Plasma Vapor Deposition (PVD)-coated.

Hardened power cylinder features midstop cylinder liners, dual piston-cooling nozzles and an anti-polish ring. Reduced piston ring temperatures increase wear resistance and power cylinder life.



Strong Bottom End

Crank, bearing and rod strengths are higher than industry requirements, providing exceptional durability.

A passenger train is shown in motion, traveling from left to right across a wide, open landscape. The train consists of two white locomotives at the front, followed by several passenger cars. The background features rolling hills and a range of mountains with patches of snow under a blue sky with scattered white clouds. The foreground is filled with tall, golden-brown grass.

The QSK95 is one of the first engines ready to meet EPA Tier 4 and EU Stage IIIB very low emissions regulations for locomotives. With this new engine and Cummins aftertreatment, you can be sure your locomotive meets the toughest national or local requirements for clean, low-noise, smoke-free operation and lower CO₂ output.

More
Traction.



A Better Train Of Thought.

For locomotive builders looking for a new-power approach to achieve cleaner, more efficient performance, the QSK95 engine arrives on time to deliver radically improved power capability for both freight and passenger operations.

With over 4000-hp (2983 kW) output from 16 cylinders, the QSK95 surpasses other high-speed engines. In terms of emissions capability and compact installation, the QSK95 is way ahead of much larger medium-speed engines with a similar output.

For commuter and intercity locomotives, the 4200-hp (3132 kW) capable QSK95 is applied with an auxiliary Cummins rail engine to provide electrical hotel power to the passenger coaches.

The QSK95 is built ultra-strong with a long life-to-overhaul and can be rebuilt multiple times.

High power density, together with Cummins space-saving exhaust aftertreatment, creates a lighter, fully integrated emissionized power solution designed to meet all of the requirements for new high-speed passenger locomotives. Operators of multipurpose freight locomotives from 3500 hp (2610 kW) will find the QSK95 is a cost-effective and very dependable power solution – keeping train operations on schedule.

The QSK95 delivers even more fuel savings to line-haul freight applications when used together with a smaller Cummins locomotive engine for full pulling power when you need it, and the best possible fuel economy at lower power levels. A smart power-sharing system transfers work between the two engines to match the locomotive duty cycle, so that overall fuel and operational costs are significantly reduced – an advantage that represents a better train of thought over current conventionally powered locomotives.

Cummins own exhaust aftertreatment system is purpose-designed for locomotive installations, using Selective Catalytic Reduction (SCR) technology. This unique, modular system minimizes space claim and improves fuel efficiency, lowering the overall cost of operation.

Without exhaust aftertreatment, the QSK95 engine meets Tier 3 locomotive emissions and is ideally suited for locomotives operating anywhere in the world, however tough the conditions. The engine is built ultra-strong for this purpose, with very long life-to-overhaul offering a major reduction in total life cycle costs.

The space-efficient design of the QSK95 enables easier service accessibility than is typical for engines of this output, as all key cooling, oil and fuel system components are externally engine-mounted, providing rapid access.

QSK95



Ultra-Class Mining Power.

The QSK95 is ready for today's largest 360-ton and 400-ton payload trucks – while offering the inherent capability to move the mining industry forward to even higher payloads with the next generation of trucks.



With its 4000-hp (2983 kW) rating, the QSK95 delivers the optimum power-to-weight ratio for mining trucks. The current output of the engine is well within its design capabilities, with potential power increases available in the future.

More efficient fuel injection works to deliver faster power delivery and combines with a single-stage quad-turbocharging system to boost transient response. As a result, the QSK95-powered haul truck will accelerate faster under full payload and climb steep haul roads in less time.

But that's only half the productivity story. For operators, it's not just about moving more tons of payload faster – it's about keeping that payload moving with no unscheduled engine downtime and at the lowest possible cost of operation.

We've examined every aspect of the QSK95 architecture, its systems and its components and have taken a no-compromise approach to using the very best techniques and materials.



The goal is to take engine uptime and availability to a new level for mining, even for the most severe duty cycles.

Maintenance is faster and easier when it is needed – and service intervals are extended to a 500-hour minimum.

The QSK95 is ready to meet Tier 4 Final and Tier 2 emissions standards. For locations where Tier 4 emissions standards apply, we intend to replace the standard exhaust muffler with a Cummins Selective Catalytic Reduction (SCR) aftertreatment system.

Designed to deliver more productivity and lower costs, the QSK95 sets a new standard for all mining engines.

An aerial photograph of a yellow mining haul truck driving on a wide, dirt road. The road is flanked by large, light-colored mounds of earth or rock. The truck is positioned in the lower center of the frame, moving away from the viewer. The lighting is bright, casting long shadows from the truck and the mounds.

The QSK95 is the only 16-cylinder high-speed diesel in the mining industry to reach 4000 hp (2983 kW) – previously possible only from 20-cylinder engines. It is designed to be the most productive engine ever built for ultra-class haul trucks.

More
Hauling.

More Drilling.



Built with enhanced strength and added reliability, Cummins QSK95 offshore-drilling power module sets new standards for uptime availability by providing prime power with nonstop dependability under the toughest duty cycles. Power delivery is more rapid, smoother and quieter than any other engine in its class.

Offshore Power For The Petroleum Industry.

Oil and gas operators take on the arduous challenge of offshore drilling and production wherever vital reserves can be found in the world. With an increasing need for higher electrical loads for deeper drilling and higher production facility load factors, operators are looking for stronger and more efficient diesel power modules.



The QSK95 engine meets offshore-drilling power requirements by delivering 3000-hp (2125 kW_e) output at 1200 rpm to keep operations running on moored semi-submersible drilling rigs, jackup rigs, drillships and floating and gravity-based production platforms. When maximum power is needed or sudden overload occurs, the QSK95 has deep reserves of durability to handle it with ease.

For emergency power applications, the QSK95 module ramps up in seconds to provide seamless power without interrupting operations. Designed, built, installed and serviced by Cummins, the QSK95 power module offers the confidence of a fully supported, single-company product. It is available in a cost-effective, standard base package, with the option of easy customization to meet your specific installation needs.

The control system comes with a full suite of operational data, multilingual touch screens and safety protection features, providing easy interface with the rig's local network and remote monitoring.

The QSK95 high-speed diesel has a significant advantage over medium-speed engines. Overall space envelope can be reduced by as much as 40 percent, together with a 33 percent weight reduction, compared with a typical medium-speed installation with a similar output. For drilling rigs and platforms featuring up to five or six power modules, this translates into a major installation advantage.

As a global engine platform, the QSK95 power module can be used anywhere your drilling operations take you. When very low Tier 4 marine and similar emissions regulations come into effect, Cummins is ready with a Selective Catalytic Reduction (SCR) aftertreatment system intended to replace the exhaust muffler. This means no change to the cooling or ventilation requirements of the power module to meet challenging emissions levels.





Meeting Critical Energy Needs.

The C3000 Series is ready to meet the increasing need for high-output gensets to provide critical power protection without interruption, required by facilities such as data centers, hospitals and utilities. In developing countries, the need to support gaps in the power grid infrastructure with larger diesel gensets is key to supporting economic growth. For mining, oil, gas and other projects in remote locations, the need for dependable microgrids generating cleaner, lower-cost power makes the C3000 Series genset an attractive option.

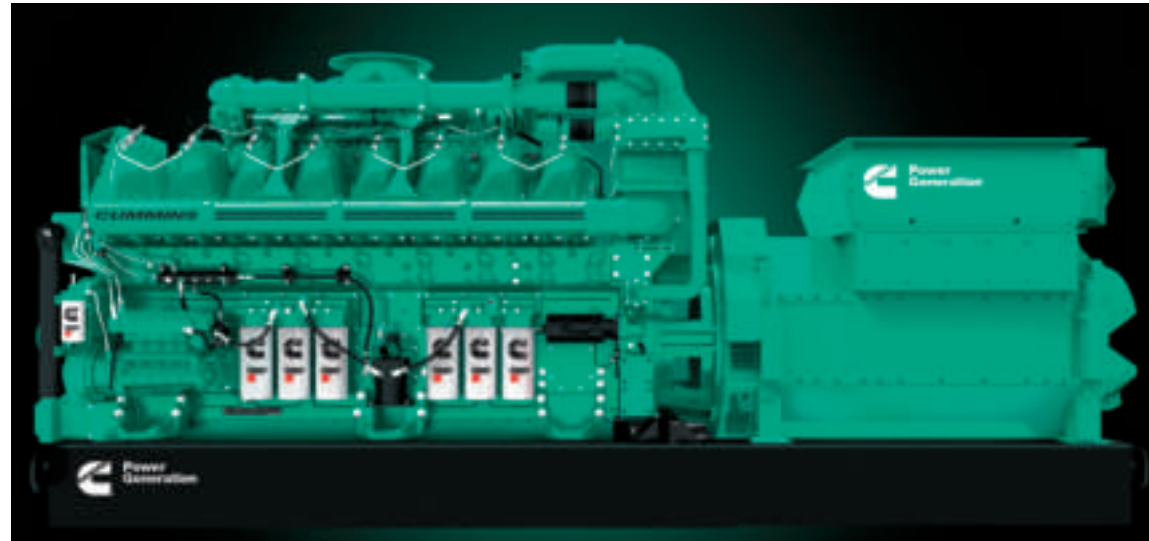

The 16-cylinder QSK95 engine realizes a reduced installation footprint and cost advantage for the C3000 Series compared with other high-speed gensets needing 20 cylinders to achieve the same power output.

This packaging efficiency becomes even more pronounced when compared with gensets using much larger medium-speed engines.

The C3000 Series genset fully leverages Cummins "Power Of One" capability. All key systems, including engine, alternator and controls, are designed and manufactured in-house, ensuring the most efficient packaging and the highest level of system integration in the industry.

We take this integration advantage even further with our own exhaust aftertreatment solutions intended to replace the exhaust muffler to meet Tier 4 and other very low emissions standards.

The C3000 Series genset seamlessly fits within Cummins large-power project expertise, with individual projects delivered and commissioned with almost 200-MW output. These major multi-genset sites are found throughout the world. Operating in challenging locations, at high altitude, in severe cold or extreme heat, they remain up and running with outstanding records of dependability.

The new C3000 Series genset powered by the QSK95 extends the capability of Cummins Power Generation to 3.5 MW – a major leap forward in power installation efficiency – realizing significantly higher economies of scale and improved life cycle costs for larger-size, multiple-set applications.

More Megawatts.



More Power Options.



Your goal is to earn a profit, so the need to have vessels with the best capital cost, low cost of operation, and reliable, durable engines is without question. That's why Cummins has developed the QSK95 marine engine with 3200-4000 hp (2386-2983 kW) ready to meet future emissions regulations and deliver exceptional fuel efficiency.

Growing In Power With Changing Vessel Requirements.

The power previously exclusive to medium-speed engines is now available in the QSK95 to meet changing power and technology requirements. The QSK95 provides an ideal solution for high-hour, hardworking vessels such as tugs, inland waterway towboats, offshore support vessels, passenger transport, dredges, short sea cargo and coastal tankers, allowing Cummins to grow with current and new customers with greater power needs.

The QSK95 offers flexibility in power configurations for propulsion, auxiliary, genset and diesel electric applications, and customers will see a significant reduction in capital investment and



installation cost compared with medium-speed engines. Extended service and more cost-effective rebuilds add a further economic advantage.

Minimizing Environmental Impact.

The QSK95 meets IMO Tier 2 and EPA Tier 3 emissions standards with highly efficient fuel injection and clean combustion. For more stringent emissions-regulated areas around the world, the QSK95 leads the way forward for 4000-hp (2983 kW) marine engines to achieve EPA Tier 4 emissions standards using Cummins own exhaust aftertreatment systems. This uniquely integrated solution offers highly efficient packaging and reduces space constraints.

The QSK95 is engineered for environmental stewardship, meeting Green Passport requirements for zero disposal impact.

Cummins QSK95 is backed by the largest and most capable engine parts and service network in the world.

QSK95

Further, the Cummins ELIMINATOR oil filtration system eliminates the need for lube oil filters, while on-engine fuel filter replacement cartridges make for more cost-effective maintenance and disposal.

Tailored Solutions.

Vessel owners, shipyards and naval architects have told us they want a team approach when considering engines, options and how to best accomplish a project. With countless successful regionally and globally coordinated projects to our credit, Cummins understands these requirements. Our teams assigned to QSK95 marine projects will work closely with the customer, shipyard and naval architect to ensure long-term benefits.

An engine with more power and more options to meet changing customer needs.



More To Come.

The QSK95 is the start of a whole new engine platform for Cummins. A “Ready For More” platform that extends from 16 cylinders up to 20 cylinders and down to 12 cylinders – with the benefits of sharing common architecture and systems.

The 16-cylinder QSK95 is pre-engineered to add four cylinders and achieve over 5000 hp (3728 kW) and generate more than 4 MW with the QSK120 engine, to become, by far, the most powerful high-speed diesel.



**The new platform
will extend to the
20-cylinder QSK120.**

The V12, V16 and V20 platforms are purpose-designed from the start to evolve into natural gas engines. A natural progression that’s ready to phase in as demand for gas engines continues to increase, giving more choices to customers.

Multiple Rebuilds.

The Cummins QSK95 is designed for multiple rebuilds on a highly economic basis. We have made major investments in establishing certified Master Engine Rebuild Centers around the world to meet the growing demand for lower-cost but high-quality engine rebuilds within the life cycle. For some applications, rebuilds will be done “in-situ.” So we have planned for this in our QSK95 product design with in-situ rebuild capability. Using unique processes, tools and training, our service technicians are able to optimize the rebuild operation.

Ready For Tier 4.

The QSK95 is a true global engine for your operations – capable of meeting all emissions regulations and robust enough to work anywhere in the world.

The QSK95 is ready to meet Tier 4 and other very low emissions standards, using in-cylinder clean combustion to reduce Particulate Matter (PM) emissions and Selective Catalytic Reduction (SCR) aftertreatment to reduce Oxides of Nitrogen (NOx) emissions. A modular design enables the SCR system to be used on all Cummins high-horsepower engines, with the intention of replacing the exhaust muffler. Engine installation remains the same, with no change to cooling requirements. Using SCR also enables better fuel efficiency of 5 percent and above to be achieved, depending on application. For the most severe low emissions standards, the QSK95 aftertreatment system can incorporate PM-reduction technology, using proven Cummins systems.

1900
6000
2000

One of the greatest strengths of owning Cummins-powered equipment is our global distributor network, with over 600 locations in 190 countries and territories. In remote areas, we deploy rapid-response teams and processes that are able to get the right technical support to help customers when they need it. Our distributors are committed to providing world-class support, and their teams of dedicated technicians are trained on and equipped with the latest diagnostic tools. Cummins is focused on providing engines with the highest possible availability and the lowest possible operating cost. In every industry, everywhere around the globe, you can rely on **Cummins. Every Time.**



Strength In Numbers.

190 countries and territories

600 company-owned distributor and independent distributor locations

20 high-horsepower engine rebuild centers

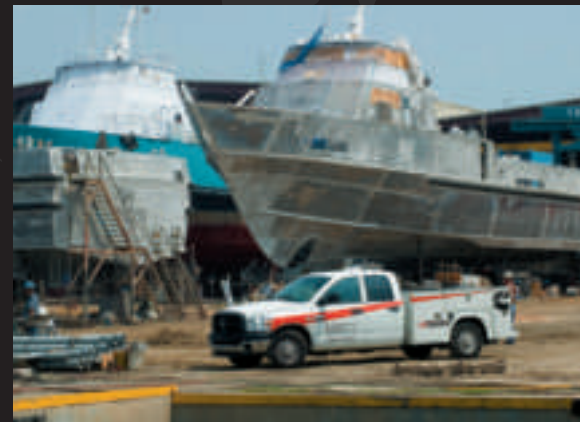



Cummins Inc.
Box 3005
Columbus, IN 47202-3005
U.S.A.

Phone: 1-800-DIESELS™ (1-800-343-7357)
Fax: 1-800-232-6393
Internet: cumminsengines.com

[Twitter.com/CumminsEngines](https://twitter.com/CumminsEngines)
[YouTube.com/CumminsEngines](https://www.youtube.com/CumminsEngines)

Bulletin 4087227 Printed in U.S.A. 10/11
©2011 Cummins Inc.